

**New York State Department of Environmental Conservation
Division of Spills & Response**

625 Broadway, 11th Floor
Albany, NY 12233-7020

Phone: (518) 402-9549 • **FAX:** (518) 402-9577

Website: www.dec.state.ny.us

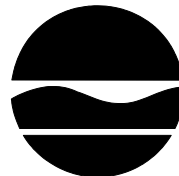

Erin M. Crotty
Commissioner

MEMORANDUM

TO: Regional Water Engineers
Regional Solid and Hazardous Waste Engineers

SUBJECT: Permanent Closure of Petroleum Storage Tanks

DATE: January 20, 1987

MODIFIED: July 19, 1988, December 3, 2003

Since the Petroleum Bulk Storage Regulation became effective on December 27, 1985, our Department has received numerous calls from the owners requesting information on closure and tank removal. Most of the questions concern whether or not tanks should be cleaned prior to removal, and how to comply with State and Federal regulations regarding the ultimate disposal of the tank and any waste products removed from the tank.

Statewide, there are thousands of tanks being removed, largely due to the Bulk Storage Regulations. Very few of these tanks are being disposed of properly. Neither the scrap yards nor the landfills are willing to accept these tanks because of fire and explosion hazards and lack of clear-cut guidance from DEC.

It is important that the Department establish a timely policy which addresses both regulatory requirements and industry standards for tank cleaning and removal. The following step-by-step procedures provide practical and cost effective guidance on this subject.

Permanent Closures of Petroleum Storage Tanks

1.01 Purpose

This guidance document provides information on procedures to be followed when permanently closing a tank or facility.

2.0 General Guidance

Where the owner of a petroleum tank or facility intends to permanently close it he must notify the Department within thirty (30) days prior to closure. In addition the owner must comply with the requirements outlined in 6 NYCRR 613.9(b). CLOSURE OF TANKS PERMANENTLY OUT-OF-SERVICE.

Tank entry, if required to remove residual sludges from the storage of heavy fuel oils, and closure of tanks are very dangerous procedures. Tanks that contain gasoline residues are explosive. All sources of ignition must be controlled and the tank's interior volume must be made inert. Tanks should only be entered by trained and properly equipped personnel and tanks should not be entered without positive ventilation and standby personnel. Petroleum vapors are heavier than air and will "hang" in the tank. The American Petroleum Institute (API) and National Fire Protection Association (NFPA) references listed at the end of this memorandum provide further information on safety precautions.

The following is a step-by-step procedure for the permanent closure of a petroleum storage tank. The procedures outlined in specific to underground gasoline storage tanks. Oil storage tanks should be treated in a similar way except for differences noted in the following:

3.0 Procedures for Removal of Underground Tanks

1. Remove all product to its lowest draw-off point (Figure 1).
2. Drain and flush piping into the tank (one or two gallons of water should be sufficient).
3. The liquid below the draw-off point is a "tank bottom" and must also be pumped out. The use of a handpump or a vacuum pump is needed. About 6" of liquid remains in the tank below the lowest draw-off point; this is equivalent to 150 gallons for a typical 4,000 gallon tank. This liquid consists of a floating layer of product, water and sediments (Figure 2). Pump out the entire tank bottom including the remaining product layer. The petroleum product can later be reclaimed through physical separation.
4. Dig down to the top of the tank and expose the upper half of the tank.
5. Remove the fill tube and disconnect the fill, gauge, product and vent lines. Cap or plug open ends of lines which are not to be used further.
6. Temporarily plug all tank openings, complete the excavation, and remove the tank, placing it in a secure location. Tank must be blocked to prevent movement.

Fig. 1

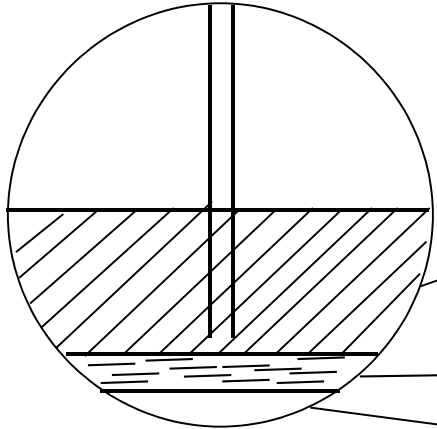

PRODUCT

WATER

SEDIMENT

Remove product to it's lowest draw-off level

Fig. 2

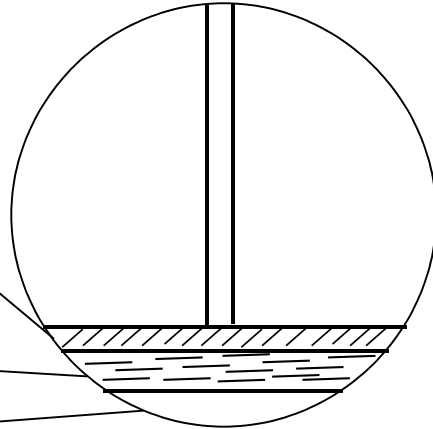

Drain and flush piping into tank.
Pump out entire tank bottom into a drum

Fig. 3

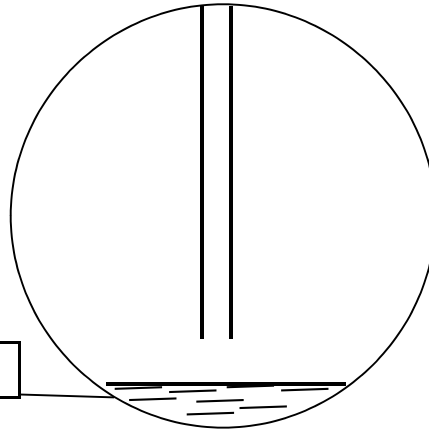

SEDIMENT & WATER

Rinse with water and remove residuals with hand or high volume vacuum pump. The tank is now empty.

7. The tank should be made safe by using one of the following methods. In all methods, the tank atmosphere should be checked to ensure that petroleum vapors have been satisfactorily purged from the tank. (See 3.0 8).
 - a. Addition of dry ice; 1.5 pounds per 100 gallons of tank capacity. The dry ice should be crushed and distributed evenly over the greatest possible area of the tank's interior. As the dry ice vaporizes flammable vapors will flow out of the tank. Therefore, observe all safety precautions regarding flammable vapors.
 - b. An alternative to dry ice is to introduce CO₂ gas directly into the tank (via the fill line) to purge flammable vapors. A minimum of one 75 lb. cylinder of CO₂ gas per 2000 gallons of tank volume should be used. Care must be exercised to prevent buildup of any static charge. The nozzle must be bonded or grounded and the gas introduced slowly to reduce static.
 - c. The use of a nitrogen gas is another acceptable method for inerting a tank. Vapors within the storage tank must be displaced with an amount of nitrogen gas equal to or greater than the volume of the tank atmosphere. Bonding or grounding of the nozzle or hose to prevent static buildup is recommended.
 - d. Positive ventilation using an air eductor is another method of purging flammable vapors from a tank. This is a very dangerous procedure and is not recommended for on-site purging of flammable vapors especially in high density urban areas.

During any tank purging operation ignition sources must be controlled. A safer alternative may be to cap the tank and plug all corrosion holes leaving a 1/8" hole for pressure relief and haul the tank to a secure area where it can be safely degassed. This alternative should only be allowed where an explosion meter check shows that the interior is vapor rich and therefore above the upper explosive limit or where the explosion meter shows that flammable vapors are below the LEL (Lower Explosive Limit) (See 3.0, 8). Tank should also be clearly marked "not gas freed".

NOTE: If desired, the tank may be degassed prior to removal from the excavation (Step 6). If this option is selected, one must carefully check the tank interior and the excavation for flammable vapors to insure that such flammable vapors have been satisfactorily removed. In this case, the vent line must remain connected and open until the purging procedure is complete.

NOTE: Federal regulations under the authority of the U.S. Department of Transportation (49CFR Section 172.500 et seq.) also require that tanks which have been purged but are being transported must be properly placarded on the ends and sides with a "Flammable" placard with the appropriate UN Number (1203 or 1993) attached.

8. The tank atmosphere must be tested to ensure that the tank is safe.

If one of the first three methods (7a, b or c) was chosen to inert the tank, the tank interior should be tested with an oxygen meter. The oxygen meter will give a reading of % oxygen per volume. For a safe condition, the reading should be 6 - 7% oxygen.

If the last method (7d) was chosen to purge the tank, the tank interior should be tested with a CGI or an explosion meter. The explosion meter will give a reading of % LEL (Lower Explosive Limit). For a safe condition the reading should be 10-20% LEL.

If the tank is not in a safe condition, then the purging or inerting process must be continued until the tank tests safe.

9. Tanks can be cleaned at this point (see 3.0, 12) or moved to a tank storage yard for cleaning. If the tank is to be moved to another site prior to cleaning, it must be transported by a licensed waste transporter (See 6.0, 1).
10. Before the tank is moved from the site plug or cap all holes. Use screwed (boiler) plugs to plug any corrosion leak holes. One plug should have a 1/8 - inch vent hole to prevent the tank from being subjected to an excessive pressure differential caused by extreme temperature changes.
11. The tank should be secured to a truck for transportation to a disposal or temporary storage site. The tank should be secured so that the vent hole is at the uppermost point of the tank. Tanks should be stored only long enough to clean and cut them up or otherwise process them for final disposal as described in Step 12. It is recommended that tanks should not be stored for a period greater than ninety days prior to final disposition.
12. The final step is to dispose of the junked tank. Once properly emptied* and cleaned, petroleum storage tanks are not a hazardous waste and hence, may be disposed of at a landfill permitted under part 360 or at a scrap yard.

In order to make a tank acceptable for disposal at a scrap yard or sanitary landfill, or if the tank will be put to use for another purpose (such as a holding tank), the following steps should be taken.

1. The tank interior should be cleaned by a high-pressure spray rinse. The water collected from this operation should be disposed of in the same manner as the tank bottoms. Please refer to section 6.0.
2. A tank which is being discarded should then be cut into several pieces to make it acceptable for disposal at sanitary landfill or scrap yard.

Any residues or solid wastes should be collected and disposed of in accordance with solid and/or hazardous waste regulations.

NOTE: The cleaning process described in step a. is acceptable for all storage tanks except for large #5 or #6 fuel oil storage tanks. The tar and sludge remaining in these tanks must be removed by manual cleaning methods. Tank entry for cleaning requires protective clothing, auxiliary air and masks for personnel

involved. If leaded fuel was stored, particular attention should be given to API publication 2015A.

4.0 Tank Abandonment In Place

The following is a safe method for abandonment of underground tanks in place. Abandonment in place is usually less costly than removal; however, this is not necessarily so when proper procedures for abandoning tanks are carefully followed. We strongly encourage tank removal over abandonment in place.

The following conditions may prohibit abandonment of underground tanks in place.

1. Local regulations specify tank removal.
2. The tank is suspected of having leaked as a result of documented evidence. Evidence such as inventory records and/or tank test results may be used.

*For purposes of this policy “Empty” shall be defined as in 6NYCRR Part 371. Section 371.1(f)(2)(i). investigate the site and perform cleanup of

3. During the tank closure process product or product contaminated soil or ground water is discovered. The tank may have to be removed to contaminated soil.

If abandonment in place is selected then the following steps must be taken.

1. Remove all flammable liquid which can be pumped out.
2. Drain and flush piping into the tank.
3. Remove tank bottoms and any remaining product as described under step 3 for tank removal.
4. Remove the fill (drop) tube. Disconnect the fill gauge and product lines. Cap or plug open ends of lines which are not to be used further. The vent line should remain connected until the tank is filled.
5. The tank should now be purged of flammable vapors as described in tank removal, step 7, section 3 above.
6. As soon as the petroleum vapors are satisfactorily purged from the tank, cut one or more large holes in the tank top. This can be accomplished by drilling a hole into the tank and using a backhoe to tear a “three-point” hole into the tank.
7. At this point, the tank interior should be cleaned with a high pressure rinse using as little water as possible to remove loose scale, corrosion and residual product. In the case of a fuel oil storage tank where large amounts of sludge and/or tar may be present, it may be necessary to enter

the tank and manually remove such wastes. As noted earlier, all safety precautions should be taken and the wastes recovered and drummed for proper disposal.

8. A visual observation of the tank interior should be made; if any holes are discovered, then a soil sample from under the tank near the hole should be taken for examination for the presence/absence of petroleum. If petroleum is present in the soil then it must be reported as a spill to the DEC within two hours. The presence of product may require the installation of one or more ground water monitoring/recovery wells or removal of the tank to take remedial action to clean up the site.
9. Proceed to introduce a suitable, solid, inert material through the hole in the top of the tank until full. Sand or a concrete slurry is recommended.
10. Disconnect and remove the vent line.
11. The owner of the tank should keep a permanent record of the tank location the date of abandonment and the method of conditioning the tank for abandonment.